

Air Knight[®] WITH IPG

IONIZED PARTICLE GATHERING

SUBMITTAL

AIR PURIFICATION SYSTEM

The Air Knight[®] Air Purification System is designed to be installed into an existing HVAC system and provide virtually maintenance free air purification. Please read and follow all service procedures outlined in the manual.

Dimensions: See Fig.1

Weight:
Approx. 3 lbs.

Warranty:
5-yr ballast. 2-yr cell.

Electrical:

The unit uses an electronic power module. The device must be installed in compliance with all national and local electrical and mechanical codes.

Power Ratings: 24V 50/60 Hz.

Output: 19.2 Watts

Temperature:

45 F - 150 F (Outside of duct).

Airflow:

7" Unit - Up to 2000 CFM.

14" Unit - Up to 3000 CFM.

Air flow specification subject to pollutant levels.

Fig. 1 Dimensions of Air Knight unit.

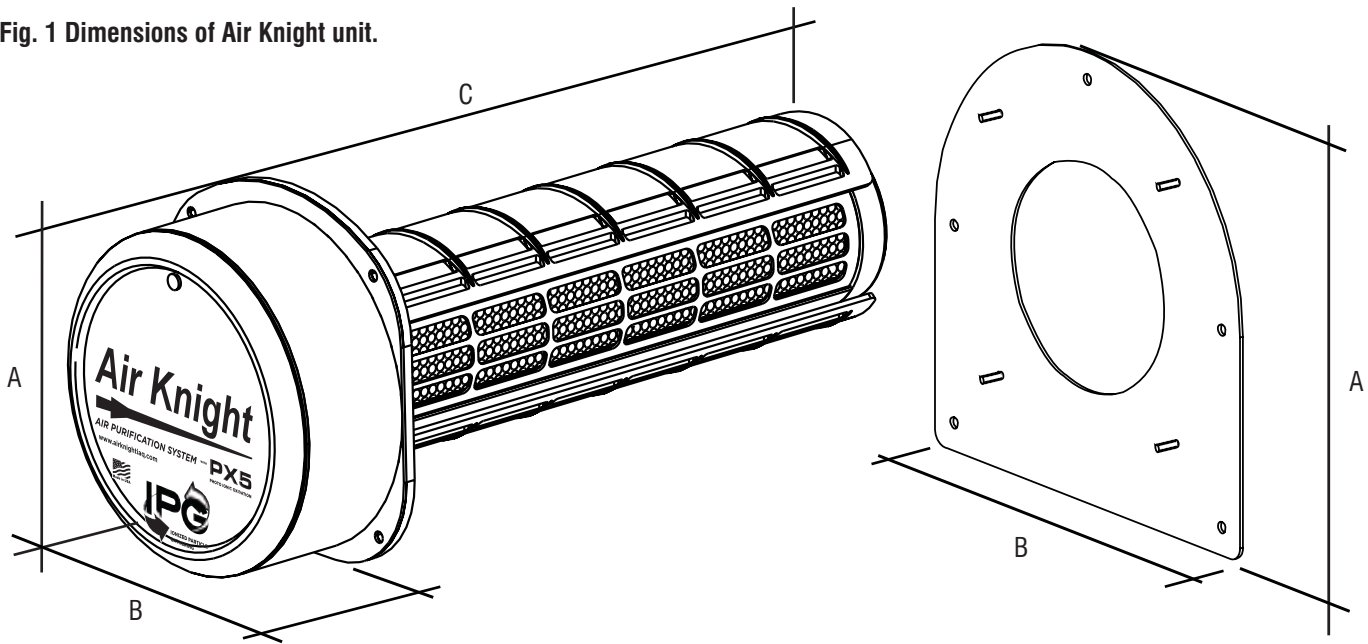

MODEL	DIM. A	DIM. B	DIM. C
7" Unit	6.5"	6"	9.9"
14" Unit	6.5"	6"	14.5"
M. Plate	7.875"	7.875"	

Specifications subject to change without notice.

Date: _____

Engineer: _____

Job Name: _____

Contractor: _____

Location: _____

Submitted By: _____